

**3 ARRAY**  
scale 1:8

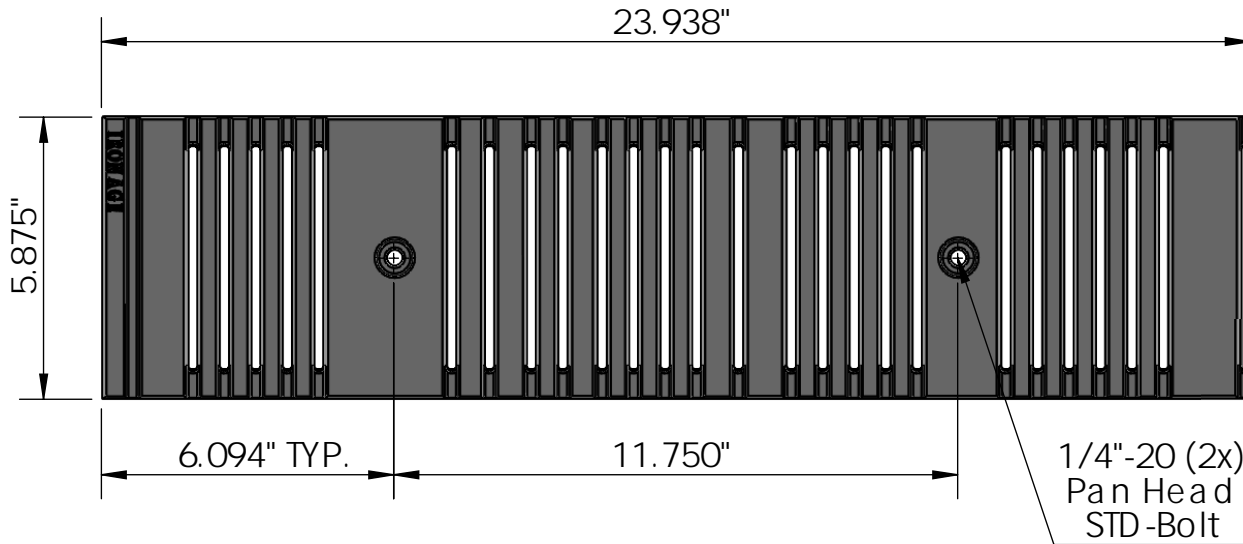

**TOP VIEW**  
scale 1:4



**CASTING-ID**  
scale 1:2



**SIDE VIEW**  
scale 1:4

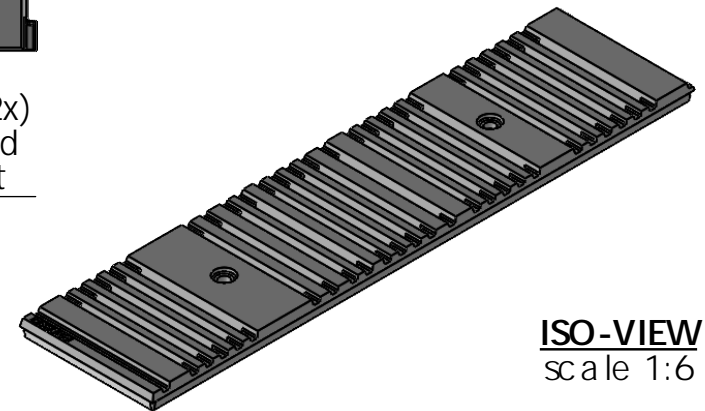
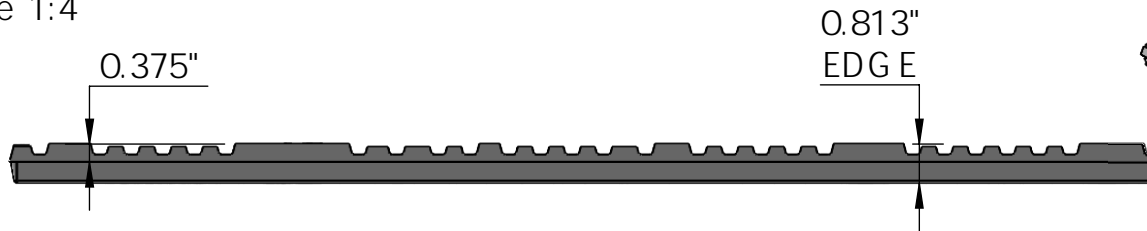

**ISO-VIEW**  
scale 1:6

**NOTES:**

1. Heelproof: No thru openings greater than 1/4".
2. Ships in pieces: 1
3. Due to casting inconsistencies, all dimensions are nominal.

Made in USA © 2024 Iron Age Designs

**Madras 6" x 24" Trench Grate - Heel Proof**

 <b>IRON AGE DESIGNS</b> Telephone 206.276.0925 www.ironagegrates.com	Material: Ductile Iron 65-45-12	Weight: 18.00 lbs.	Free Drain Area: 22.43 in/sq., or 15.95 %	By: MS	Checked: MS	Date: 6-5-25
	Finish: Raw	Edge: 0.813"	Flow Rate: 29.39 GPM, or .065 CuFt./sec.	© Registration: Pending		Scale: NTS
	Fits: NDS®Dura Slope®	Product ID: MDN6-24I03HP	Drawing Name: 01_MAD_N_6x24HP_TrenchGrate_Iron			