

END

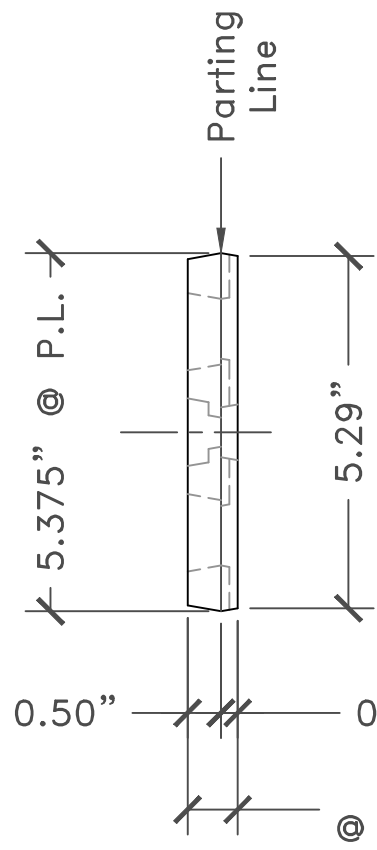

TOP

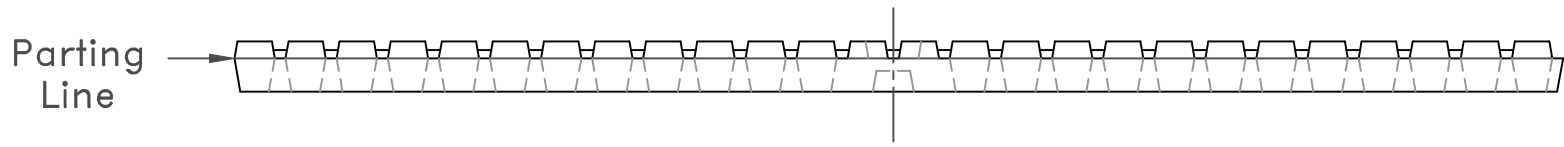
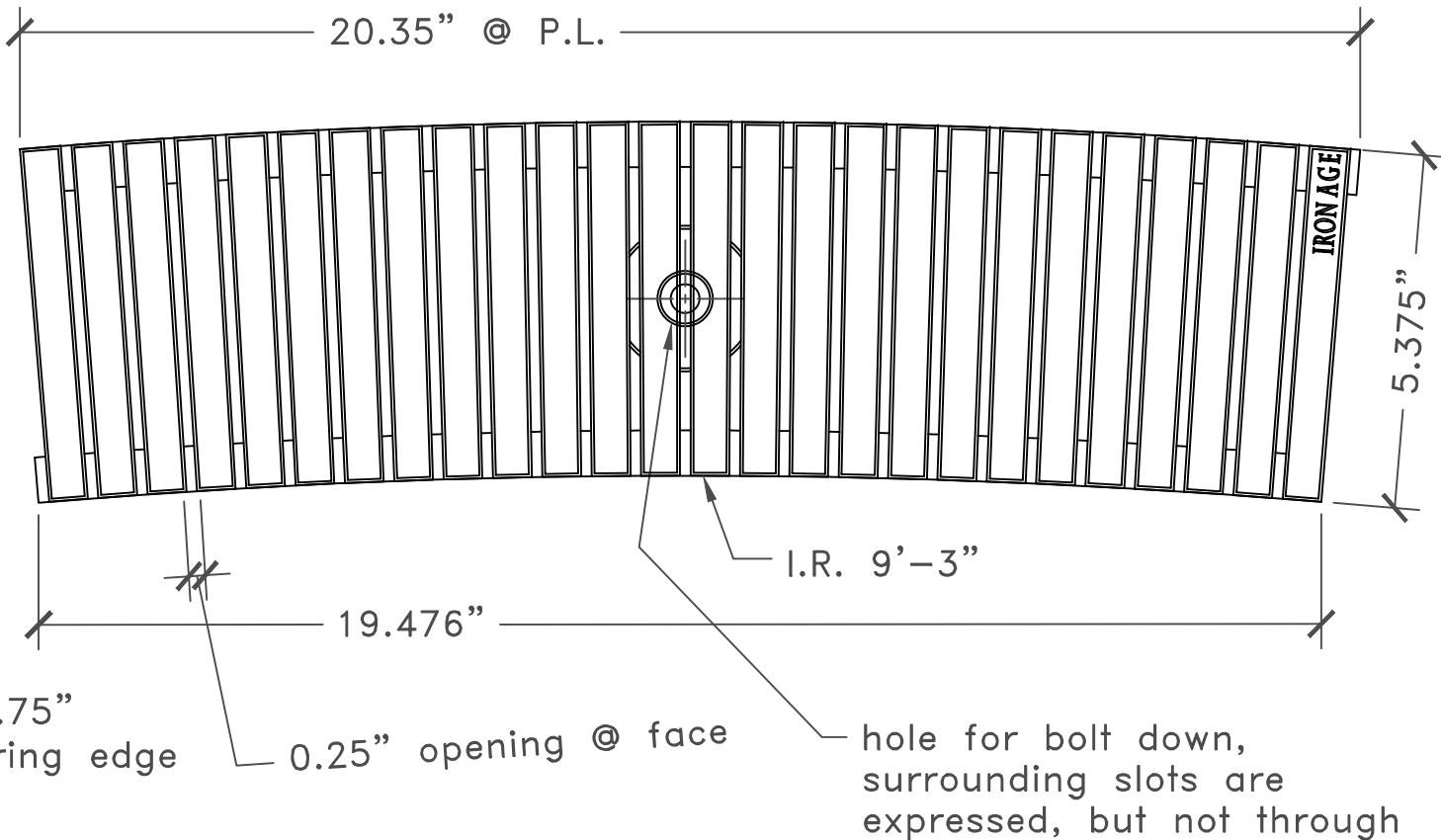

ELEVATION



IRON AGE
DESIGNS

2104 SW 152nd St. #4 TEL 206.276.0925
Burien, WA 98166 FAX 206.257.0318
www.ironagedesigns.com

NOTES:

1. Material: cast iron
2. Natural finish
3. Total thickness: 1"
4. Fits trench frame manufactured by: Iron Age™
5. No openings greater than 1/4"
6. Due to casting inconsistencies, all dimensions are nominal.

© 2010 Iron Age Designs

Regular Joe 5.38" Heel-Proof Trench Grate
9'-6" C.L.R.

drawing no. 02-JOE.Rad1

drawn by: CD
scale: NTS
date: 9/16/10