

top
scale 1:4

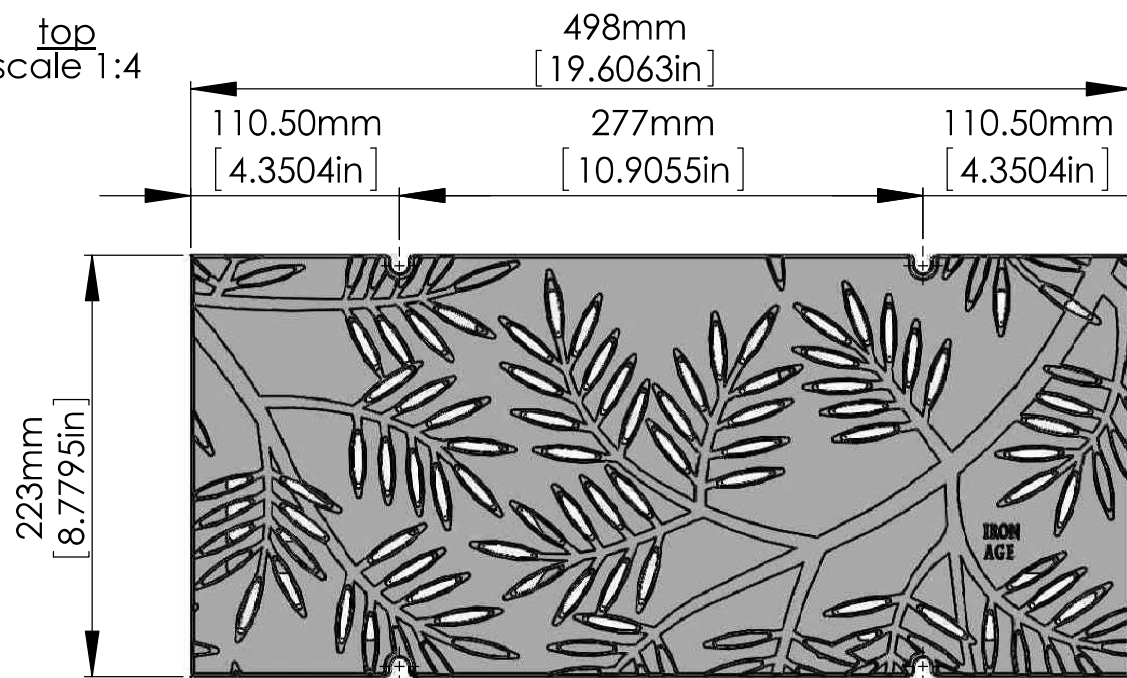

(4X) hole for m8 button-head screw, locations correspond w/ bolt-dn holes in MEADRAIN™ channel

end
scale 1:4

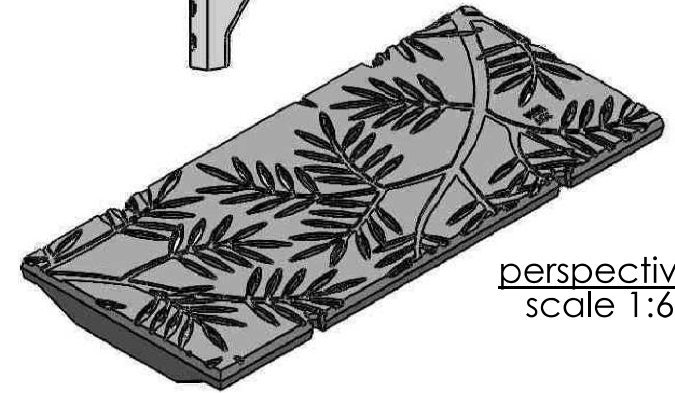
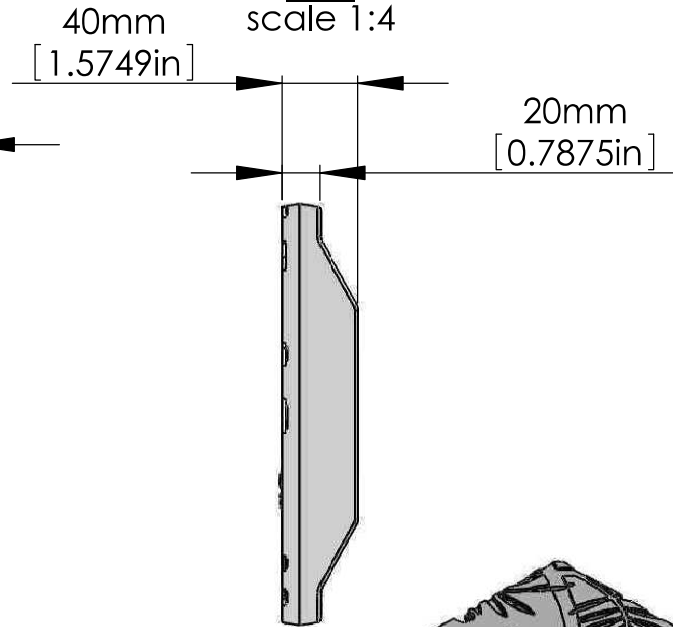

perspective
scale 1:6

edge
scale 1:4

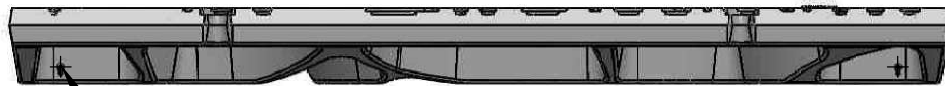

(4X) drill point to locate hole for PROFIX™

NOTES:

1. Material: cast ductile iron
2. Finish: Natural
3. Edge Thickness: 20mm/0.79"
4. Fits: MEA® EN2000/D400/E600
5. No openings greater than: 6mm /1/4" - Heel-Proof
6. Approximate weight 10.4 Kg (24.2 lbs)
7. Due to casting inconsistencies all dimensions are nominal

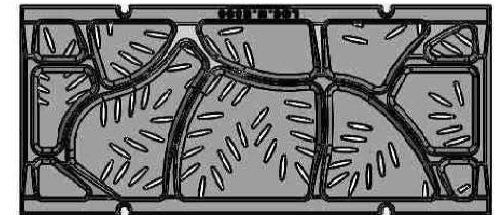

rear
scale 1:8

IRON AGE 2104 SW 152nd St. #4 TEL 206.276.0925
DESIGNS Burien, WA 98166 FAX 206.257.0318
 www.ironagedesigns.com

Locust 9"x20" Heel-Proof
Trench Grate
DWG. NO. LOC.M.E600

Drawn by: CD
Date: 01/05/06
Scale: NTS

© 2006 Iron Age Designs Registration Number: VA 1-814-274