

**3 ARRAY**  
scale 1:4

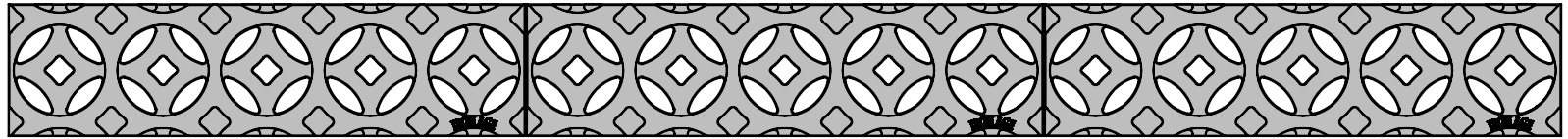

**TOP VIEW**  
scale 1:2

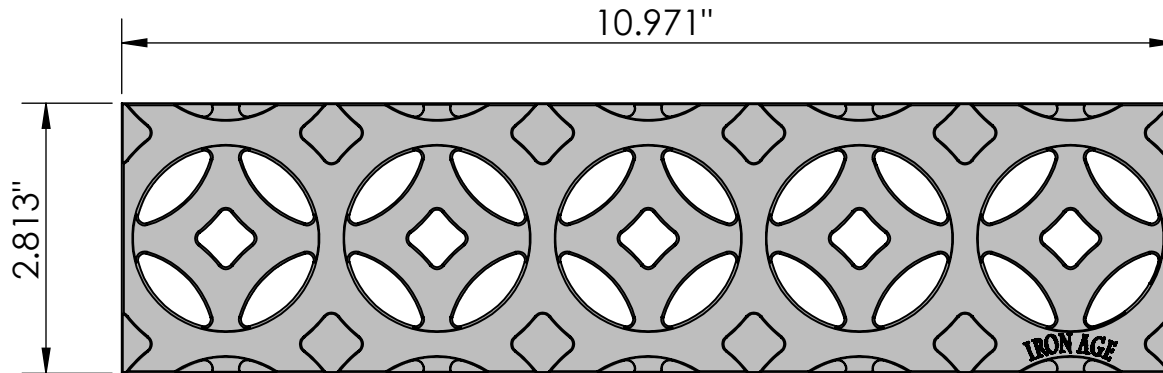

**END View**  
scale 1:2

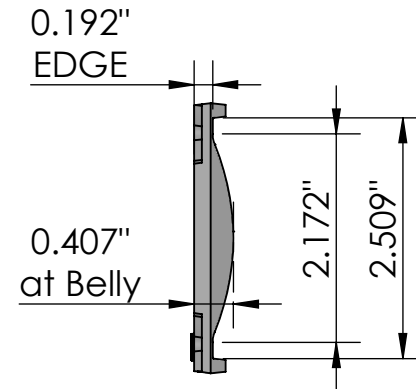

**CASTING-ID**  
scale 1:1

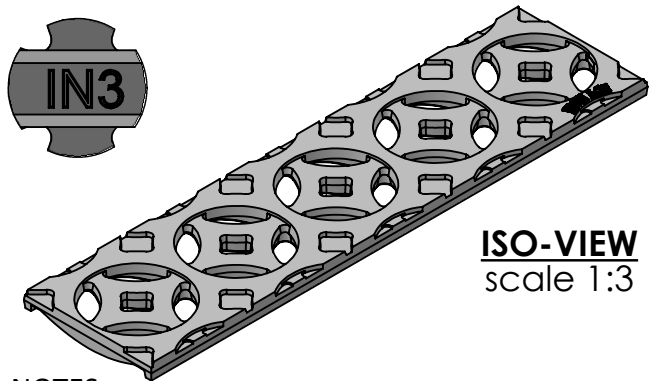

**ISO-VIEW**  
scale 1:3

**SIDE VIEW**  
scale 1:2

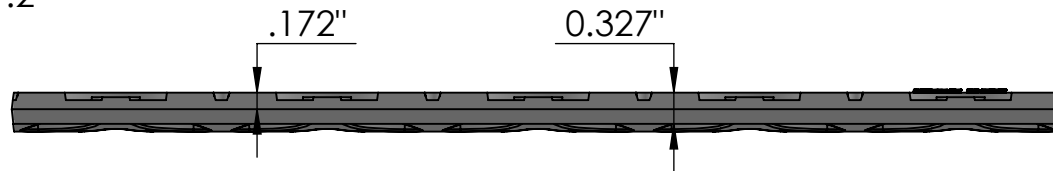

**NOTES:**

1. ADA Compliant: No thru openings greater than 1/2".
2. Ships in pieces: 1
3. Due to casting inconsistencies, all dimensions are nominal.

Made in USA ©2007 Iron Age Designs

**Interlaken 3" x 11" Trench Grate**

<p><b>IRON AGE</b> DESIGNS Telephone 206.276.0925 www.ironagegrates.com</p>	Material: Ductile Iron 65-45-12	Weight: 1.56 lbs.	Free Drain Area: 6.57 in/sq., or 21.30 %	By: MS	Checked: MS	Date: 8-20-21
	Finish: Raw	Edge: .192"	Flow Rate: 8.61 GPM, or .019 CuFt./sec.	© Registration: VA 2-007-115		Scale: NTS
	Fits: NDS® Mini Channel	Product ID: IN3-11I01	Drawing Name: 01_INT_N_3x11_TrenchGrate_Iron			